

A. MECHANICAL (unit:mm)

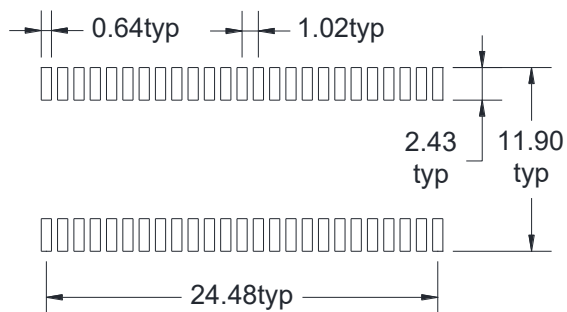

Suggested PAD Layout

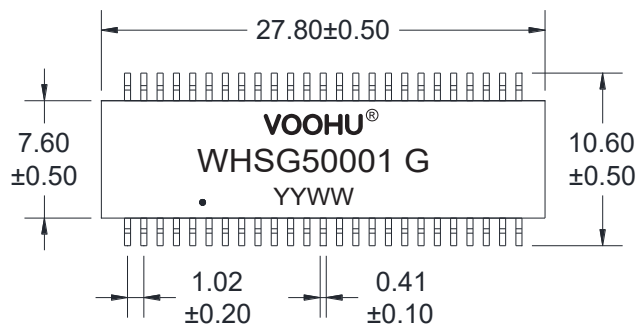
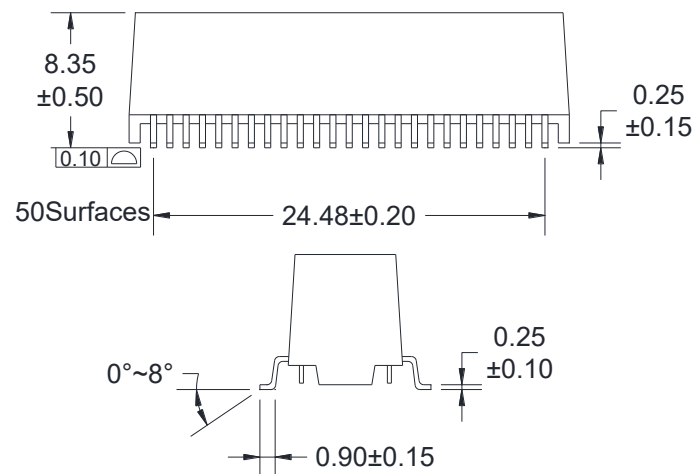

B. SCHEMATICS

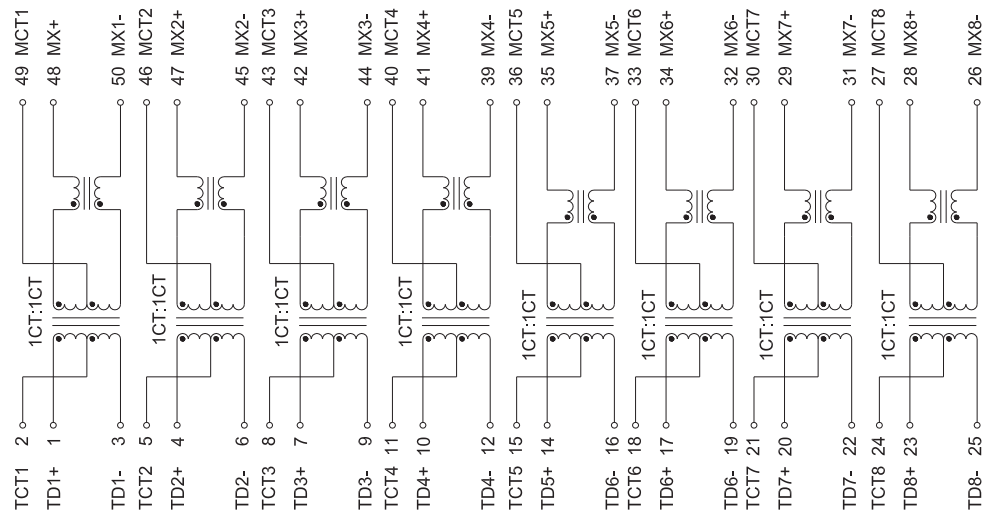

**VOOHU** 苏州沃虎电子科技有限公司  
Su Zhou Voohu Electronic Tech.Co.Ltd

TITLE:  
100/1000 BASE-T

SIZE  
A4

UNITS  
MM[INCH]

GENERAL TOLERANCES  
UNLESS SPECIFIED

APPROVED BY:  
Geoffrey.Song

PART NO.:  
WHSG50001 G

SACLE  
1:1

REV  
A0

$x \pm 0.35$   
 $.x \pm 0.30$

CHECKED BY:  
Elvis.Song

REMARK:

SHEET  
1/3

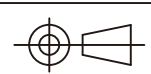

$.xx \pm 0.25$   
 $.xxx \pm 0.10$

DESIGND BY:  
Sunny.Xu

TEL: +86 400 1048 018

WEB: WWW.WOHU-TEK.COM

### C. ELECTRICAL SPECIFICATIONS @25°C

1. OCL: 350uH Min @ 100 KHz, 0.1V with 8mA DC BIAS
2. Leakage Inductance: 0.5uH Max @ 100KHz, 0.1V
3. DCR: 1400mΩ Max
4. Turns Ratio: 1CT:1CT±5%
5. Insertion Loss: -1.1 dB Max @ 1-100 MHz
6. Return Loss: -18 dB Min @ 1-30 MHz  
 -14.4 dB Min @ 40 MHz  
 -13.1 dB Min @ 50 MHz  
 -12 dB Min @ 60-80 MHz  
 -10 dB Min @100 MHz
7. Cross Talk: -30 dB Min @ 1-100 MHz
8. Common Mode Rejection: -30 dB Min @ 1-100 MHz
9. Isolation Hipot: 1500VAC 1mA 60S
10. Operating temperature 0°C to +70°C
11. Storage temperature -20°C to +125°C

### D. PACKAGE INFORMATION

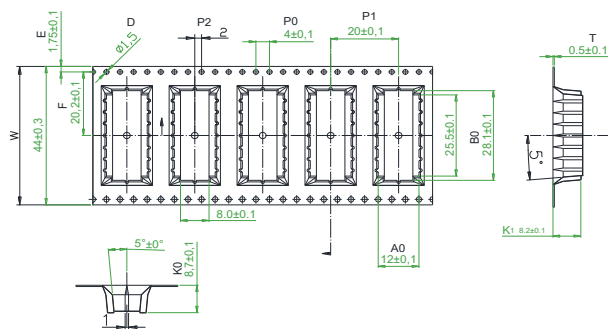

Package Quantity:  
 One Reel(1.56kg)=400Pcs  
 One Inner Carton(3.48kg)=400\*2=800Pcs  
 One Export Carton(7.78kg)=800\*2=1600Pcs

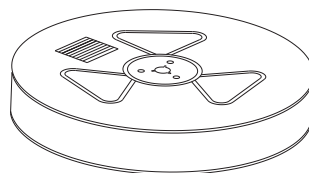
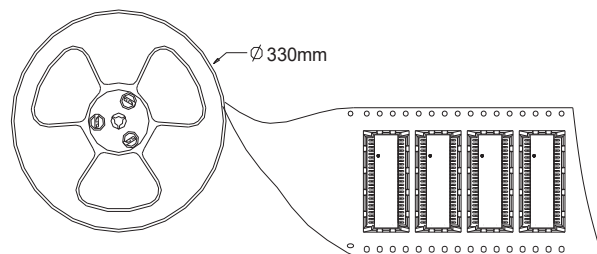

two reel

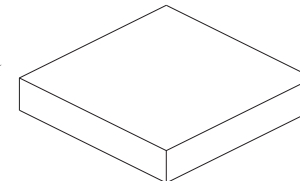

Inner Carton

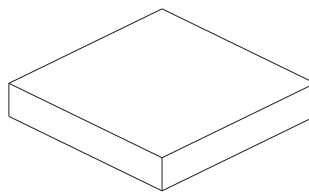

two Inner Carton

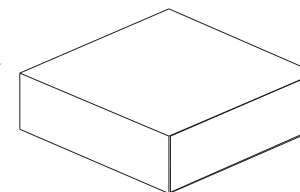

Export Carton

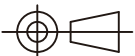
 <b>苏州沃虎电子科技有限公司</b> Su Zhou Voohu Electronic Tech.Co.Ltd	TITLE: 100/1000 BASE-T	SIZE A4	UNITS MM[INCH]	GENERAL TOLERANCES UNLESS SPECIFIED		APPROVED BY: Geoffrey.Song
	PART NO.: WHSG50001 G	SACLE 1:1	REV A0	x±0.35 .x±0.30	x°±3.0° .x°±2.0°	CHECKED BY: Elvis.Song
	REMARK:	SHEET 2/3		.xx±0.25 .xxx±0.10	.xx°±1.5° .xxx°±1.0°	DESIGND BY: Sunny.Xu
TEL: +86 400 1048 018	WEB: <a href="http://WWW.WOHU-TEK.COM">WWW.WOHU-TEK.COM</a>					

### E. RECOMMEND REFLOW SOLDERING CURVE

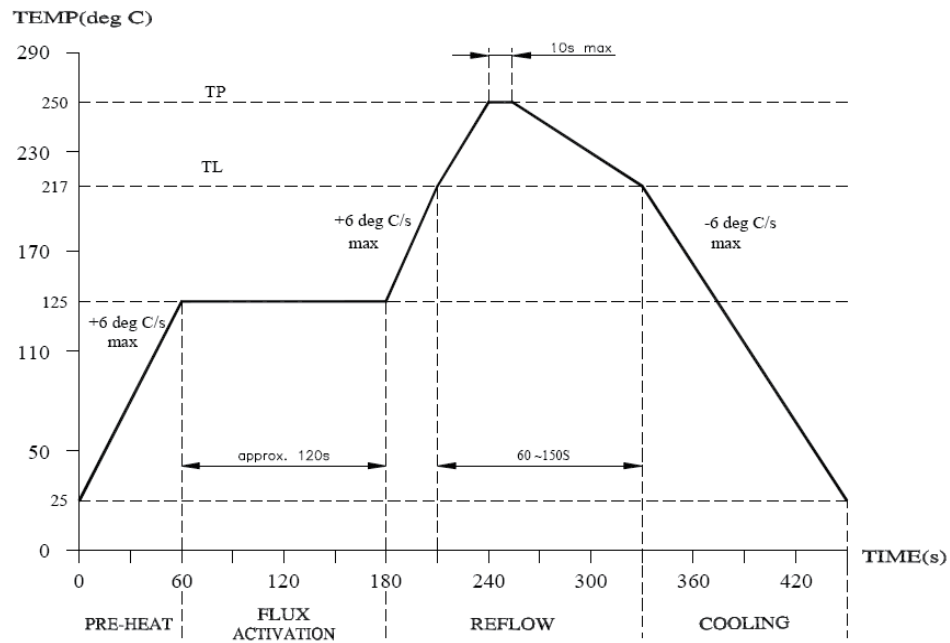

**VOOHU** 苏州沃虎电子科技有限公司  
Su Zhou Voohu Electronic Tech.Co.Ltd

TITLE:  
100/1000 BASE-T

SIZE  
A4

UNITS  
MM[INCH]

GENERAL TOLERANCES  
UNLESS SPECIFIED

APPROVED BY:  
Geoffrey.Song

PART NO.:  
WHSG50001 G

SACLE  
1:1

REV  
A0

x±0.35	x°±3.0°
.x±0.30	.x°±2.0°

CHECKED BY:  
Elvis.Song

TEL: +86 400 1048 018

WEB: [WWW.WOHU-TEK.COM](http://WWW.WOHU-TEK.COM)

REMARK:

SHEET  
3/3



.xx±0.25	.xx°±1.5°
.xxx±0.10	.xxx°±1.0°

DESIGND BY:  
Sunny.Xu