

Specification for Approval

产品承认书

Customer:

Customer P/N:

VOOHU P/N:

WHD72301G

Version No.:

V0.1

Description:

100/1000 BASE-T

Laser Marking

SUZHOU VOOHU Company Approval		Customer Approval (客户承认签章)
DRAWN	Geoffrey.Song	
CHECKED	Sunny.Xu	
APPROVED	Elvis. Song	
日期DATE::2024/7/13		日期DATE:

Please Return One Copy to Us After Approved,TKS! (承认后请回寄一份,谢谢)

VOOHU 沃虎

—— 连接世界 · 通信未来 ——

苏州沃虎电子科技有限公司
SuZhou Voohu Electronic Tech.Co.,Ltd

地址: 江苏省苏州市吴江区阿尔法大厦A栋
ADD: Building A, Alpha Building, Wujiang District,
Suzhou City, Jiangsu Province

TEL: +86 400 1048 018 WEB: www.wohu-tek.com/
+86 13338655578 E-MAIL: wohu@wohu-tek.com

A. MECHANICAL(unit:mm)

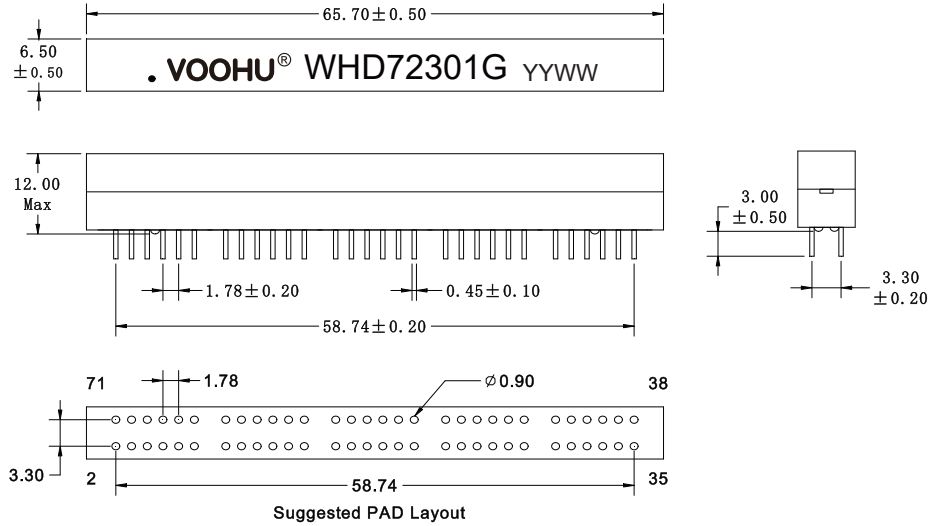

B. Schematics

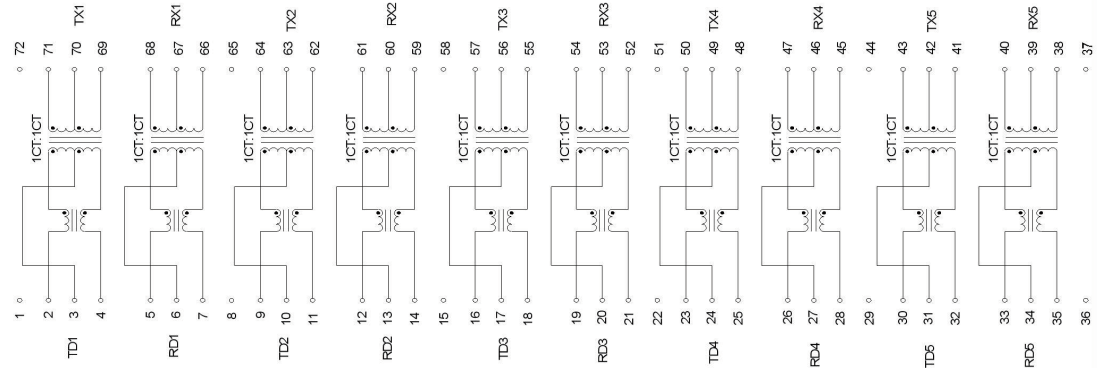

VOOHU 苏州沃虎电子科技有限公司
Su Zhou Voohu Electronic Tech.Co.Ltd

TITLE:
100/1000 BASE-T

SIZE
A4

UNITS
MM[INCH]

GENERAL TOLERANCES
UNLESS SPECIFIED

APPROVED BY:
Geoffrey.Song

PART NO.:
WHD72301G

SACLE
1:1

REV
A0

$x \pm 0.35$
 $.x \pm 0.30$

$x^\circ \pm 3.0^\circ$
 $.x^\circ \pm 2.0^\circ$

CHECKED BY:
Elvis.Song

TEL: +86 400 1048 018

WEB: WWW.WOHU-TEK.COM

REMARK:

SHEET
1/3



$.xx \pm 0.25$
 $.xxx \pm 0.10$

$.xx^\circ \pm 1.5^\circ$
 $.xxx^\circ \pm 1.0^\circ$

DESIGND BY:
Sunny.Xu

C. ELECTRICAL SPECIFICATIONS @25°C

Unless Otherwise Specified, Testing is Performed at 25°C ± 5°C

1. OCL: 350uH Min @ 100 KHz, 0.1V 8mA DC BIAS
2. Leakage Inductance: 0.5uH Max @ 100KHz, 0.1V
3. DCR: 1400mΩ Max
4. Turns Ratio: 1CT:1CT±5%
5. Insertion Loss: -1.1 dB Max @ 1-100 MHz
-14.4 dB Min @ 40 MHz
-13.1 dB Min @ 50 MHz
-12 dB Min @ 60-80 MHz
6. Return Loss: -18 dB Min @ 1-30 MHz
7. Cross Talk: -30 dB Min @ 1-100 MHz
8. Common Mode Rejection: -30 dB Min @ 1-100 MHz
9. Isolation Hipot: 1500VAC 1mA 60S
10. Operating temperature 0°C to +70°C
11. Storage temperature -40°C to +85°C

D. RECOMMEND WAVE SOLDERING CURVE

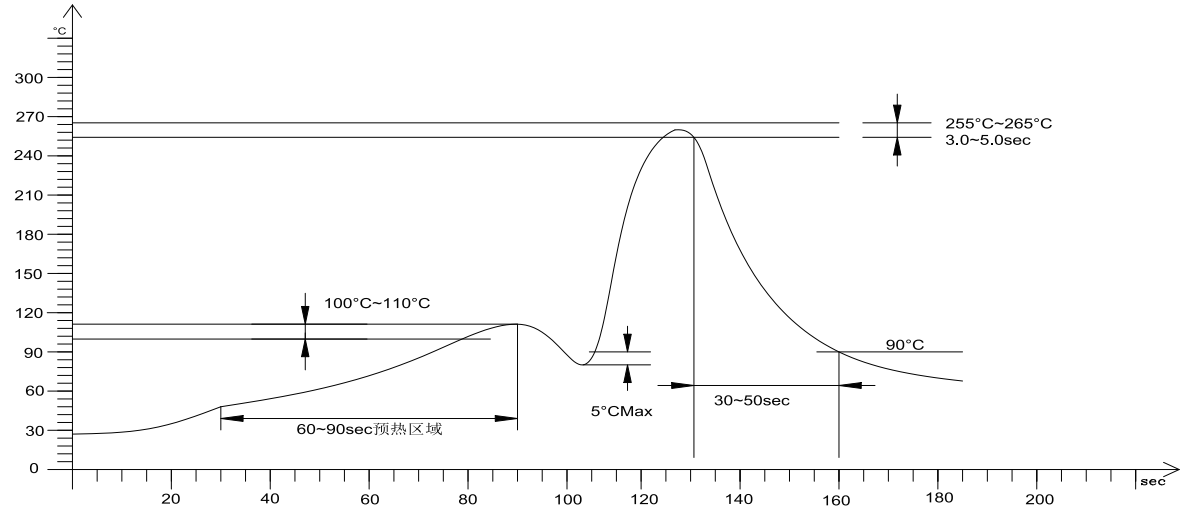

VOOHU 苏州沃虎电子科技有限公司
Su Zhou Voohu Electronic Tech.Co.Ltd

TEL: +86 400 1048 018

WEB: WWW.WOHU-TEK.COM

TITLE:
100/1000 BASE-T

PART NO.:
WHD72301G

REMARK:

SIZE
A4

SACLE
1:1

SHEET
2/3

UNITS
MM[INCH]

REV
A0

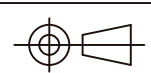

GENERAL TOLERANCES
UNLESS SPECIFIED

x±0.35	x°±3.0°
.x±0.30	.x°±2.0°
.xx±0.25	.xx°±1.5°
.xxx±0.10	.xxx°±1.0°

APPROVED BY:
Geoffrey.Song

CHECKED BY:
Elvis.Song

DESIGND BY:
Sunny.Xu

E. Packaging specification

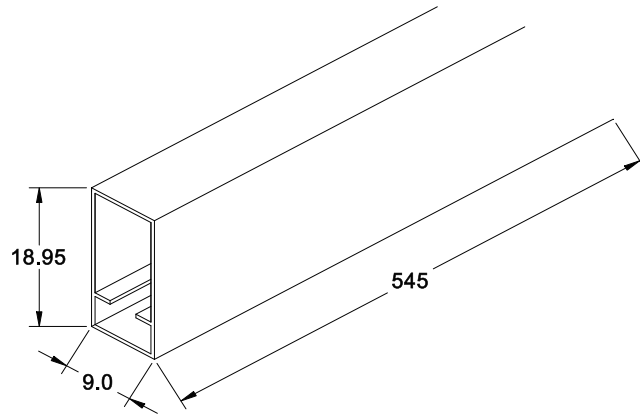

Tube: 545*9.0*18.95mm

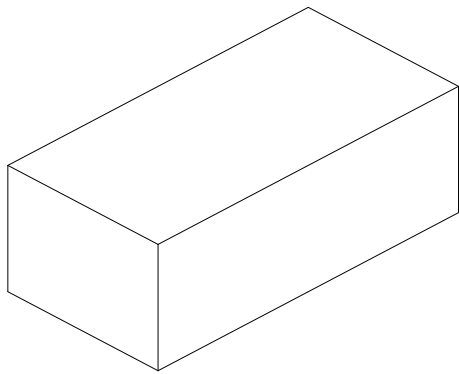

Inner Carton: L570*W180*H100mm

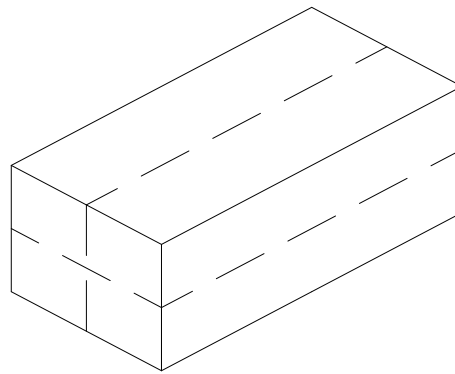

Export Carton: L580*W380*H240mm

Package Quantity:

One Tube=8Pcs

One Inner Carton=8*72=576Pcs

One Export Carton=576*4=2304Pcs

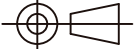
 苏州沃虎电子科技有限公司 Su Zhou Voohu Electronic Tech.Co.Ltd	TITLE: 100/1000 BASE-T	SIZE A4	UNITS MM[INCH]	GENERAL TOLERANCES UNLESS SPECIFIED		APPROVED BY: Geoffrey.Song
	PART NO.: WHD72301G	SACLE 1:1	REV A0	x±0.35 .x±0.30	x°±3.0° .x°±2.0°	CHECKED BY: Elvis.Song
	REMARK:	SHEET 3/3		.xx±0.25 .xxx±0.10	.xx°±1.5° .xxx°±1.0°	DESIGND BY: Sunny.Xu

TEL: +86 400 1048 018

WEB: WWW.WOHU-TEK.COM