

# Specification for Approval

## 产品承认书

**Customer:**

**Customer P/N:**

**VOOHU P/N:**

WHSG24301GM

**Version No.:**

V0.1

**Description:**

100/1000 BASE-T

Meet GJB9001C Standard

Compliant with IEEE 802.3ab standard.

SUZHOU VOOHU Company Approval		Customer Approval (客户承认签章)
<b>DRAWN</b>	Geoffrey.Song	
<b>CHECKED</b>	Sunny.Xu	
<b>APPROVED</b>	Elvis. Song	
日期DATE:2026/4/08		日期DATE: 2026/4/08

Please Return One Copy to Us After Approved,TKs! (承认后请回寄一份,谢谢)

**A. MECHANICAL(unit:mm)**

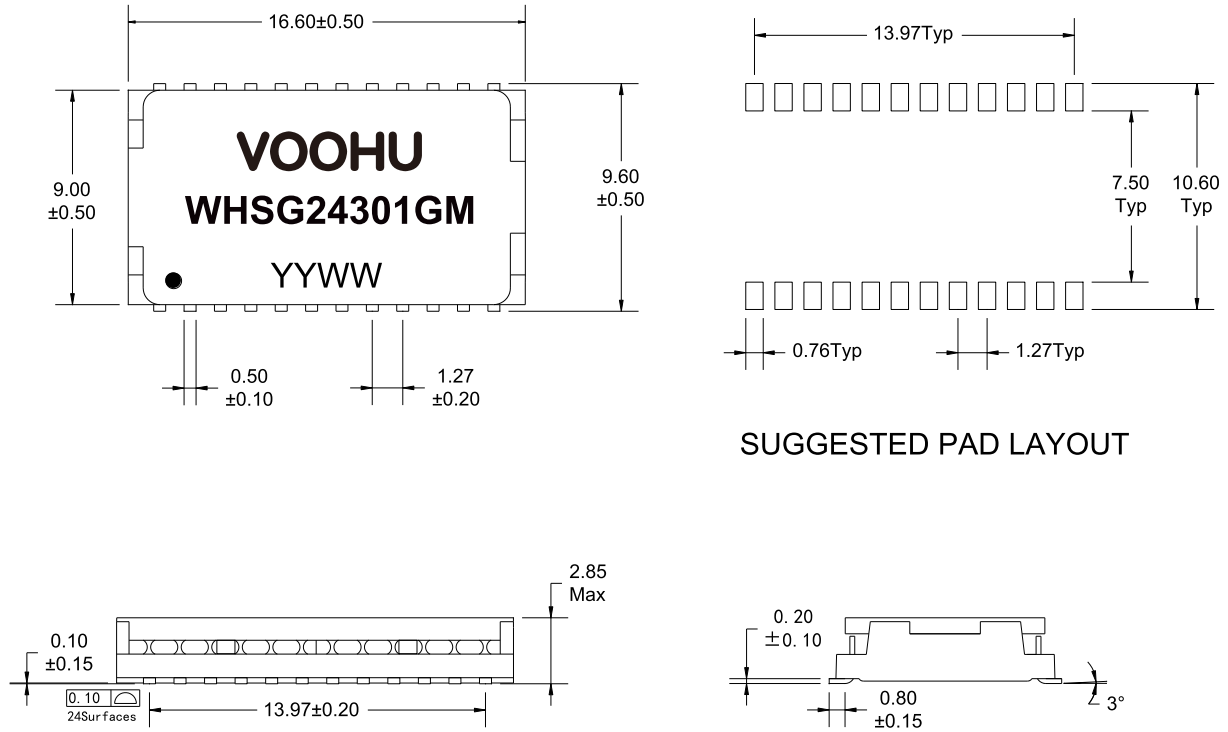

**SUGGESTED PAD LAYOUT**

**B. SCHEMATICS**

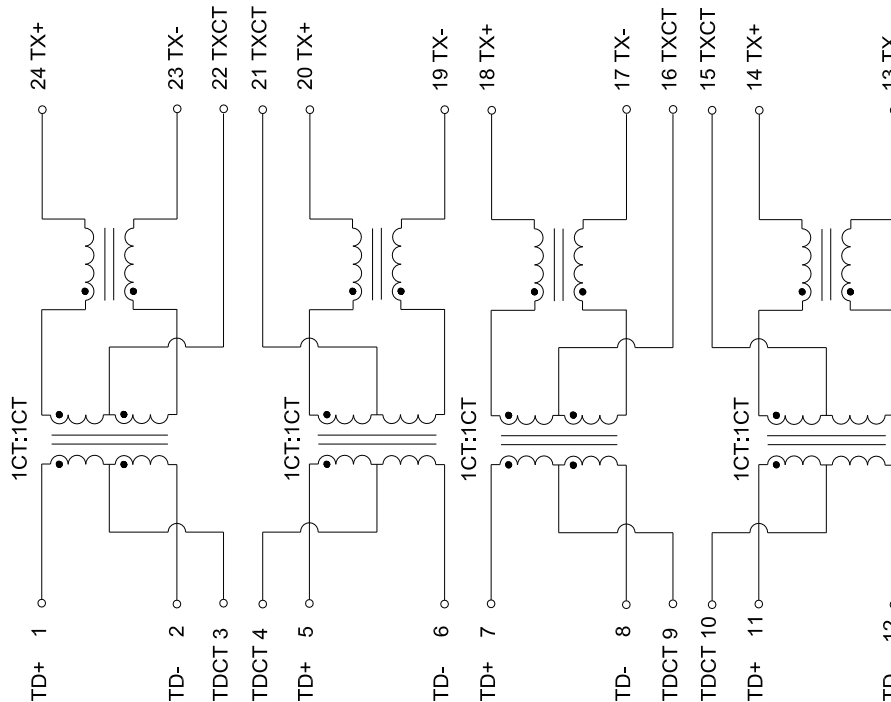

DESCRIPTION	PART NO.	REV:R0
100/1000 BASE-T	WHSG24301GM	PAGE:1/3

### C. ELECTRICAL SPECIFICATIONS @25°C

1. OCL: 350uH Min @ 100KHz, 0.1V
2. Leakage Inductance: 0.5uH Max @ 100KHz, 0.1V
3. DCR: 1400mΩ Max
4. Turns Ratio: 1CT:1CT±5%
5. Insertion Loss: -1.1 dB Max @ 1-100 MHz
6. Return Loss: -18 dB Min @ 1-30 MHz
  - 14.4 dB Min @40 MHz
  - 13.1 dB Min @ 50 MHz
  - 12 dB Min @ 60-80 MHz
  - 10 dB Min @ 100 MHz
7. Cross Talk: -30 dB Min @ 1-100 MHz
8. Common Mode Rejection: -30 dB Min @ 1-100 MHz
9. Isolation Hipot: 1500VAC 1mA 60S
10. Operating temperature -40°C to +125°C
11. Storage Temperature(With Package): +10°C to +40°C
12. Storage Temperature(Without Package, Just For Components): -40°C to +125°C
13. Compliant with IEEE 802.3ab standard.
14. Certification GJB9001C Standard
15. RoHS/REACH/HF Compliance

DESCRIPTION	PART NO.	REV:R0
100/1000 BASE-T	WHS24301GM	PAGE:2/3

### D. PACKAGE INFORMATION

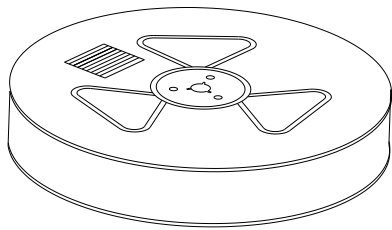
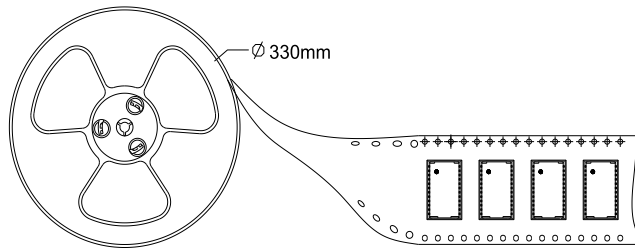
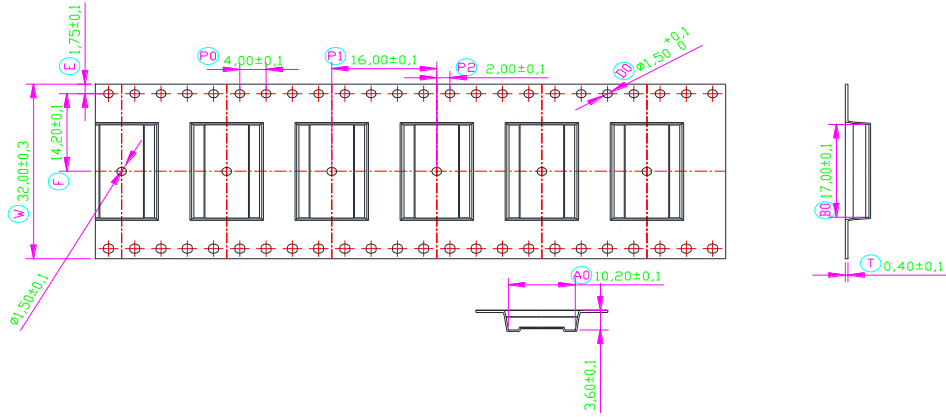

Two Reel

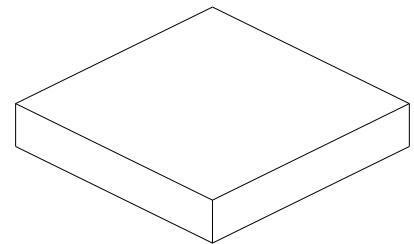

Inner Carton

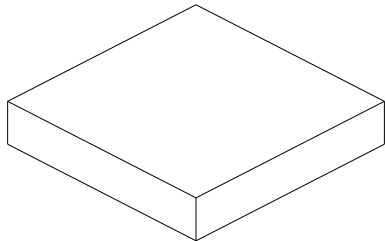

Two Inner Carton

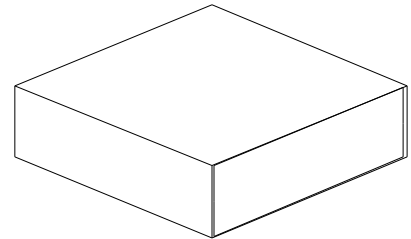

Export Carton

Package Quantity:

One Reel=1100Pcs

One Inner Carton=1100\*2=2200Pcs

One Export Carton=2200\*2=4400Pcs

DESCRIPTION	PART NO.	REV:R0
100/1000 BASE-T	WHS24301GM	PAGE:3/3