

REACH & RoHS
COMPLIANT

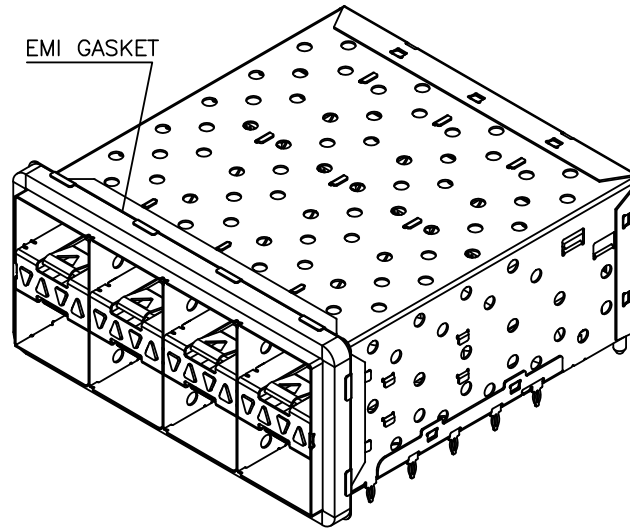
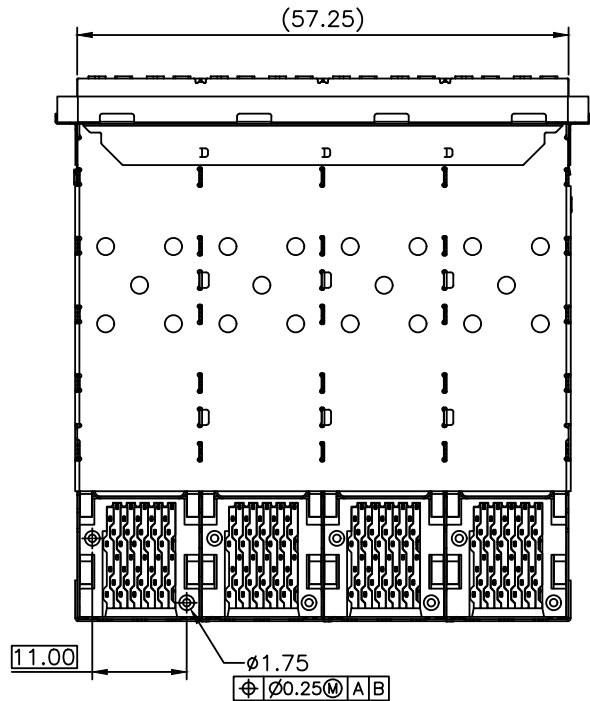
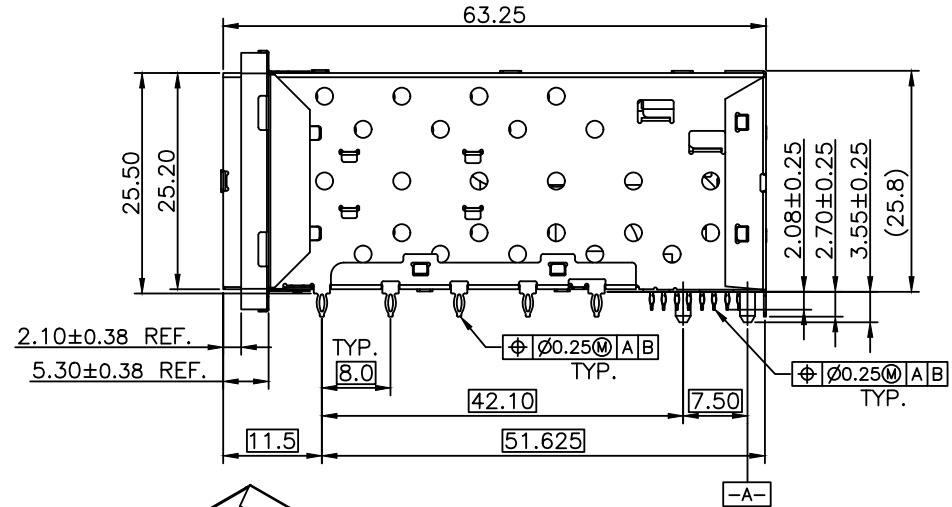
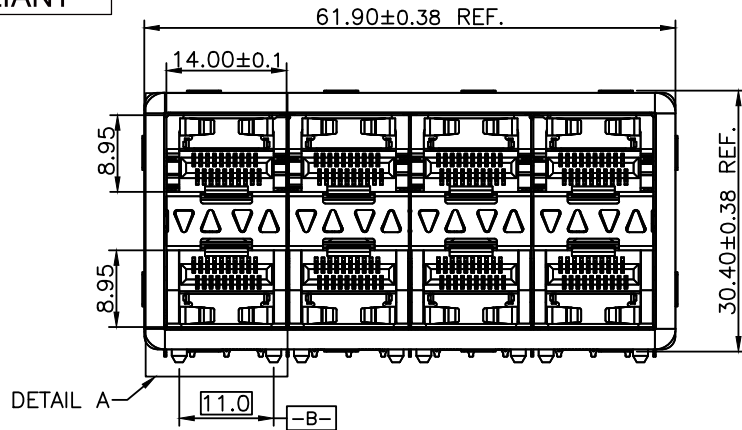

NOTES:

MATERIAL:
 CAGE: COPPER ALLOY MIN NI-PLATED, THICKNESS 0.25 MM
 EMI GASKET: SILICONE
 CONNECTOR:
 PLASTIC HOUSING: HIGH TEMPERATURE LCP, UL94 V-0.
 LIGHT PIPE: POLYCARBONATE; COLOR: CLEAR
 SPRING: STAINLESS STEEL, THICKNESS 0.20mm
 CONTACTS: PHOSPHOR BRONZE, THICKNESS 0.20mm
 PLATING: 15µ" MIN. GOLD ON MATING AREA,
 150µ" MIN. MATE TIN ON SOLDER TAILS.
 PACKAGING: TRAY PACKAGING.
 OPERATING TEMPERATURE: -40°C TO +85°C
 STORAGE TEMPERATURE: -55°C TO +105°C

VOOHU 苏州沃虎电子科技有限公司
 Su Zhou Voohu Electronic Tech.Co.Ltd

TITLE:
SFP+ 2X4 CAGE+CONNECTOR

SIZE
A4

UNITS
MM[INCH]

GENERAL TOLERANCES
UNLESS SPECIFIED

PART NO.:
WH29DTD19D1S01

SCALE
1:1

REV
A0

x±0.35
.x±0.30

x°±3.0°
.x°±2.0°

TEL: +86 400 1048 018

WEB: WWW.VOOHU.CN

REMARK:

SHEET
1/4

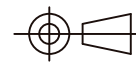

.xx±0.25
.xxx±0.10

.xx°±1.5°
.xxx°±1.0°

CHECKED BY:
Elvis.Song
DESIGNED BY:
Sunny.Xu

REACH & RoHS
COMPLIANT

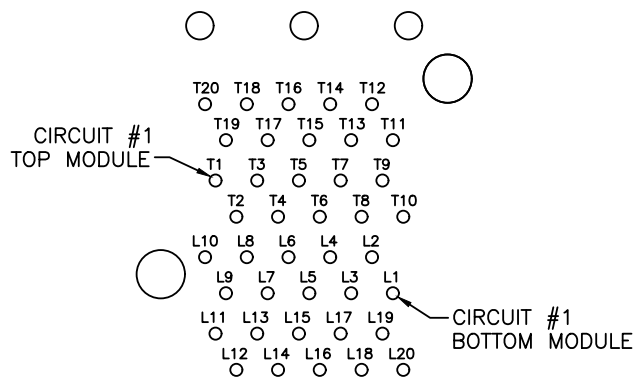

CIRCUIT NUMBERING
COMPONENT SIDE OF BOARD

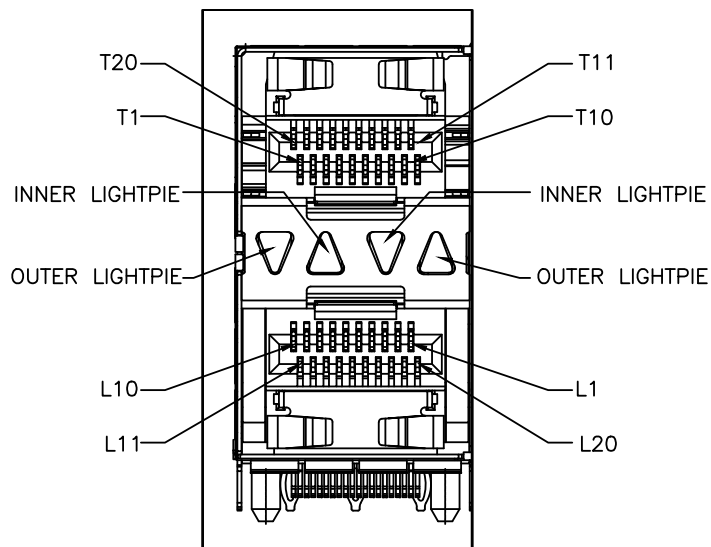

DETAIL A
CIRCUIT NUMBERING
AND LIGHTPIE IDENTIFICATION

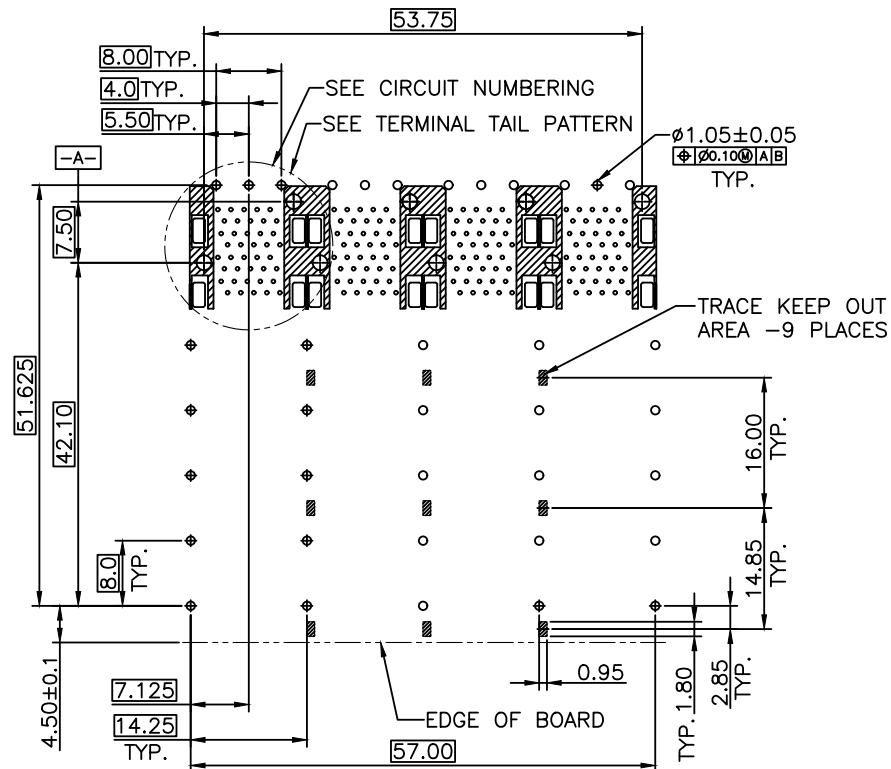

RECOMMENDED PCB LAYOUT - COMPONENT SIDE
RECOMMENDED PCB THICKNESS : 2.36MM(.093 INCH)
(MINIMUM PCB THICKNESS : 1.57)

THE ENTIRE AREA OF THE CONNECTOR FOOTPRINT
TO BE CONSIDERED THE KEEP OUT AREA FOR COMPONENTS
THIS AREA IS INDICATED BY THE DASHED LINE

TITLE:
SFP+ 2X4 CAGE+CONNECTOR

SIZE
A4
UNITS
MM[INCH]

GENERAL TOLERANCES
UNLESS SPECIFIED

APPROVED BY:
Geoffrey.Song

PART NO.:
WH29DTD19D1S01

SCALE
1:1

REV
A0

$x \pm 0.35$
 $x^\circ \pm 3.0^\circ$
 $.x \pm 0.30$
 $.x^\circ \pm 2.0^\circ$

CHECKED BY:
Elvis.Song

REMARK:

SHEET
2/4



$.xx \pm 0.25$
 $.xx^\circ \pm 1.5^\circ$
 $.xxx \pm 0.10$
 $.xxx^\circ \pm 1.0^\circ$

DESIGNED BY:
Sunny.Xu

VOOHU 苏州沃虎电子科技有限公司
Su Zhou Voohu Electronic Tech.Co.Ltd

TEL: +86 400 1048 018

WEB: WWW.VOOHU.CN

REACH & RoHS
COMPLIANT

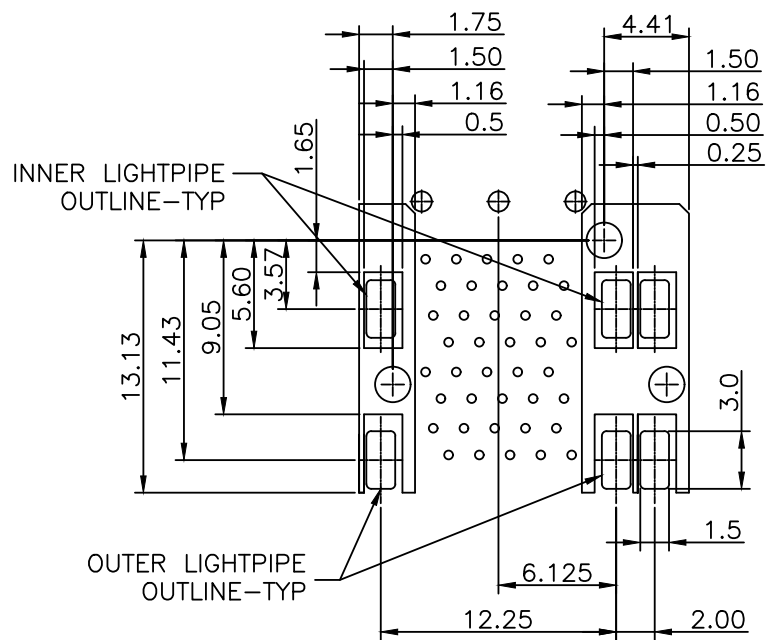

DETAIL-KEEPOUT ZONES

THE HATCHED AREA IN THIS VIEW INDICATES ZONES THAT ARE OCCUPIED BY THE PLASTIC HOUSING THAT SEATS AGAINST THE PCB AND BY THE VERTICAL METAL CAGE WALL THAT STOPS JUST SHORT OF THE PCB

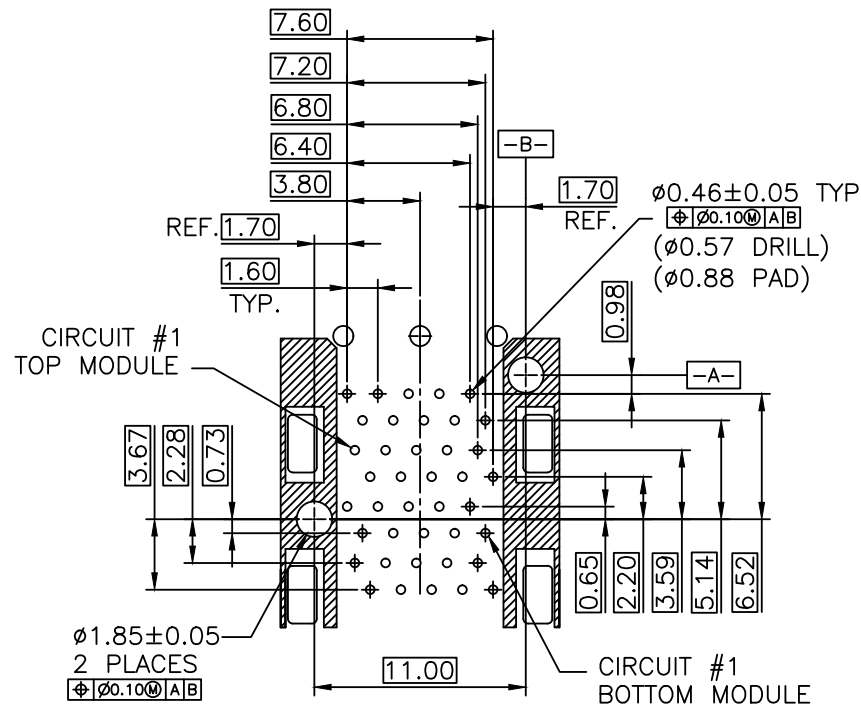

TERMINAL TAIL PATTERN

VOOHU 苏州沃虎电子科技有限公司
Su Zhou Voohu Electronic Tech.Co.Ltd

TITLE:
SFP+ 2X4 CAGE+CONNECTOR

SIZE
A4

UNITS
MM[INCH]

GENERAL TOLERANCES
UNLESS SPECIFIED

APPROVED BY:
Geoffrey.Song

PART NO.:
WH29DTD19D1S01

SCALE
1:1

REV
A0

$x \pm 0.35$
 $.x \pm 0.30$

CHECKED BY:
Elvis.Song

TEL: +86 400 1048 018

WEB: WWW.VOOHU.CN

REMARK:

SHEET
3/4





$.xx \pm 0.25$
 $.xxx \pm 0.10$

DESIGNED BY:
Sunny.Xu

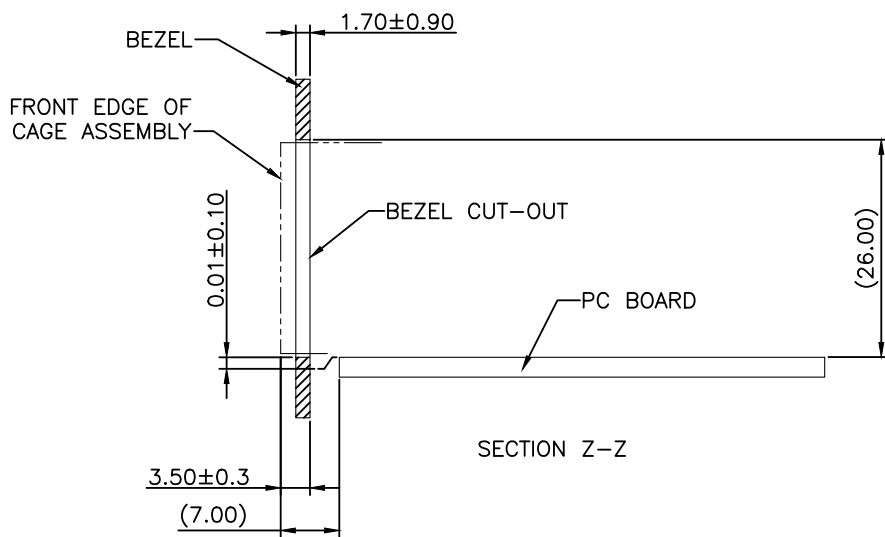
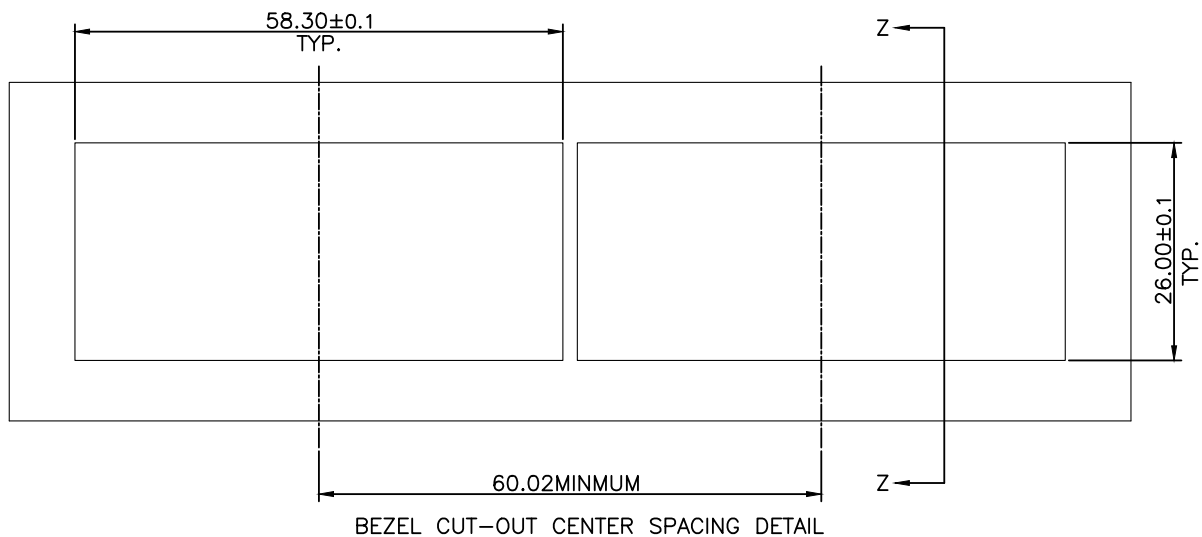
REACH & RoHS
COMPLIANT



 苏州沃虎电子科技有限公司 Su Zhou Voohu Electronic Tech.Co.Ltd	TITLE: SFP+ 2X4 CAGE+CONNECTOR	SIZE A4	UNITS MM[INCH]	GENERAL TOLERANCES UNLESS SPECIFIED		APPROVED BY: Geoffrey.Song
	PART NO.: WH29DTD19D1S01	SCALE 1:1	REV A0	.xx±0.35	.x°±3.0°	CHECKED BY: Elvis.Song
TEL: +86 400 1048 018	REMARK:	SHEET 4/4		.xx±0.25	.xx°±1.5°	DESIGNED BY: Sunny.Xu
WEB: WWW.VOOHU.CN				.xxx±0.10	.xxx°±1.0°	