

Specification for Approval

产品承认书

Customer:

Customer P/N:

VOOHU P/N:

WHSG24301JM

Version No.:

V0.1

Description:

100/1000 BASE-T

Meet GJB9001C Standard

Compliant with IEEE 802.3ab standard.

SUZHOU VOOHU Company Approval		Customer Approval (客户承认签章)
DRAWN	Geoffrey.Song	
CHECKED	Sunny.Xu	
APPROVED	Elvis. Song	
日期DATE:2026/5/09		日期DATE: 2026/5/09

Please Return One Copy to Us After Approved,TKs! (承认后请回寄一份,谢谢)

A. MECHANICAL(unit:mm)

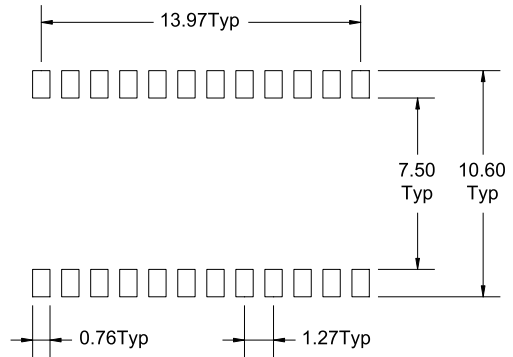
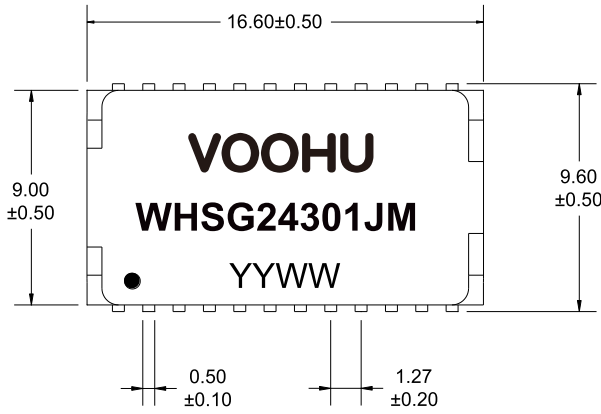

SUGGESTED PAD LAYOUT

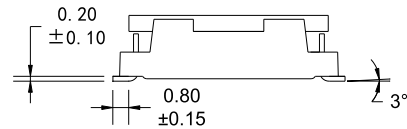
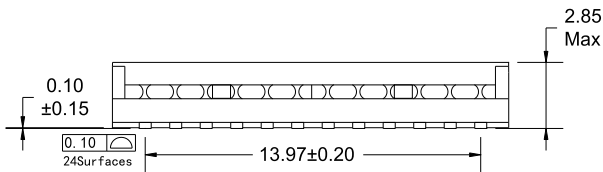

B. SCHEMATICS

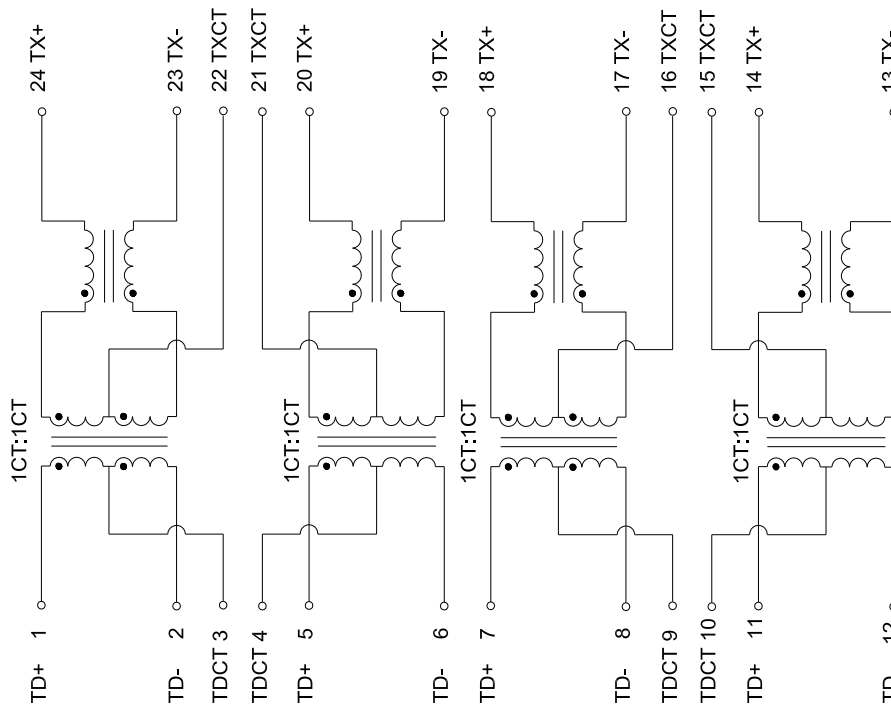

DESCRIPTION	PART NO.	REV:R0
100/1000 BASE-T	WHSG24301JM	PAGE:1/3

C. ELECTRICAL SPECIFICATIONS @25°C

1. Leakage Inductance: 0.5uH Max @ 100KHz, 0.1V
2. DCR: 1400mΩ Max
3. Turns Ratio: 1CT:1CT±5%
4. Insertion Loss: -1.1 dB Max @ 1-100 MHz
5. Return Loss: -18 dB Min @ 1-30 MHz
 - 14.4 dB Min @40 MHz
 - 13.1 dB Min @ 50 MHz
 - 12 dB Min @ 60-80 MHz
 - 10 dB Min @ 100 MHz
6. Cross Talk: -30 dB Min @ 1-100 MHz
7. Common Mode Rejection: -30 dB Min @ 1-100 MHz
8. Isolation Hipot: 1500VAC 1mA 60S
9. Operating temperature -55°C to +125°C
10. Storage Temperature(With Package): +10°C to +40°C
11. Storage Temperature(Without Package, Just For Components): -55°C to +125°C
12. Compliant with IEEE 802.3ab standard.
13. Certification GJB9001C Standard
14. RoHS/REACH/HF Compliance

DESCRIPTION	PART NO.	REV:R0
100/1000 BASE-T	WHSG24301JM	PAGE:2/3

D. PACKAGE INFORMATION

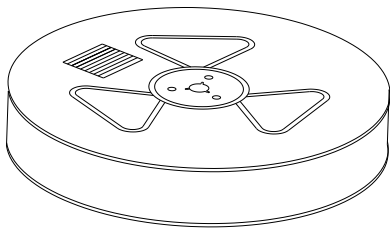
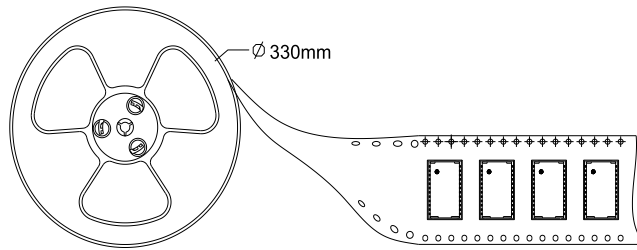
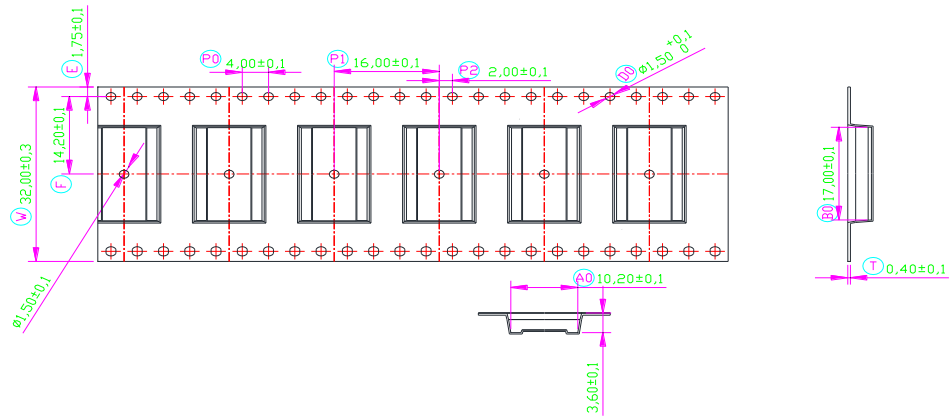

Two Reel

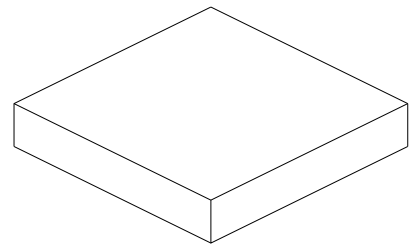

Inner Carton

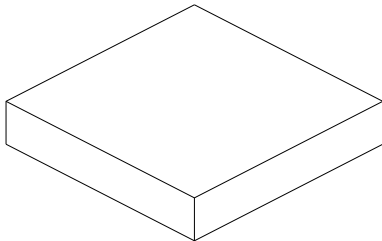

Two Inner Carton

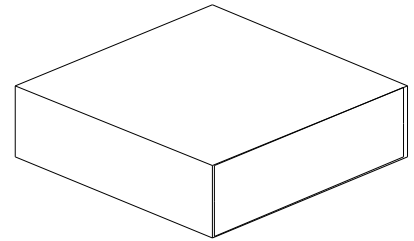

Export Carton

Package Quantity:

One Reel=1100Pcs

One Inner Carton=1100*2=2200Pcs

One Export Carton=2200*2=4400Pcs

DESCRIPTION	PART NO.	REV:R0
100/1000 BASE-T	WHS24301JM	PAGE:3/3